

低結霜

變頻

超省電



Natural Refrigerants Ultra-Low Temperature Freezer

-86°C to -40°C



725 L



New door structure to reduce frost on the inner door

PHC's New MDF-DU700ZHA reduces "frost" on the surface of the inner door. "Frost" that adheres to the inner door surface is suppressed. This reduces the time required for troublesome defrosting work. MDF-DU700ZHA is an ultra-low temperature freezer that also achieves high energy efficiency by using a natural refrigerant (non-Freon) and inverter control.

MDF-DU700ZHA

Natural refrigerants and inverter technology

Naturally occurring hydrocarbon (HC) refrigerants have minimal effect on the environment and are compliant with environmental legislation for climate control. Combined with inverter technology, these refrigerants also provide more efficient cooling without compromising cooling performance, ambient tolerance, and recovery speeds following door openings.

Inner door with vacuum insulation

The structure has been changed to an inner door with vacuum insulation material. By insulating the inside and outside of the cabinet with the inner door alone, frost on the surface of the inner door is reduced.

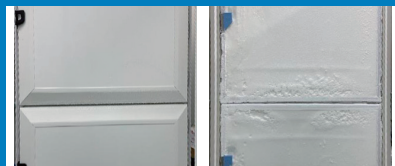

MDF-DU700ZHA

Conventional model

Multi-function LCD control panel

The 7-inch full-color LCD touch panel is accurately controlled even with a gloved hand, while the USB port makes transferring logged data of product's operational status to a PC convenient.

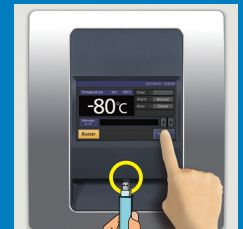

Energy efficient performance

Natural refrigerants, compressors and integrated electronics combine to lower operating costs compared to existing models by up to 53%*. Freezer operation is managed by effectively balancing temperature performance and energy management.



* Compared to conventional model

Reduced defrosting process on inner door surfaces

Are you stressed about defrosting the surface of the inner door of your ultra-low temperature freezer? PHC's model MDF-DU700ZHA reduces the time-consuming "defrosting" process.

Defrosting Process (Example)



Removing frost
Defrosting near packing reduced!

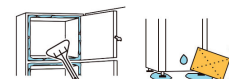

Removing frost around the packings
Defrosting labor is reduced!

One-time defrosting and wiping time
Total time
Conventional model

Approx. 16 min.

MDF-DU700ZHA

Approx. 7 min.

NB: How much frost will build up in the freezer depends on the environment where it's used.

Data log function

LCD touch panel for various operations. Graphical display of temperature history, door opening/closing history, etc. can be checked.



Natural Refrigerants Ultra-Low Temperature Freezer

MDF-DU700ZHA-PA

Performance Data

AT30°C Pull-down & Pull-up Temperature

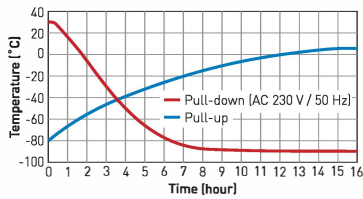

Dimensions

Unit : mm

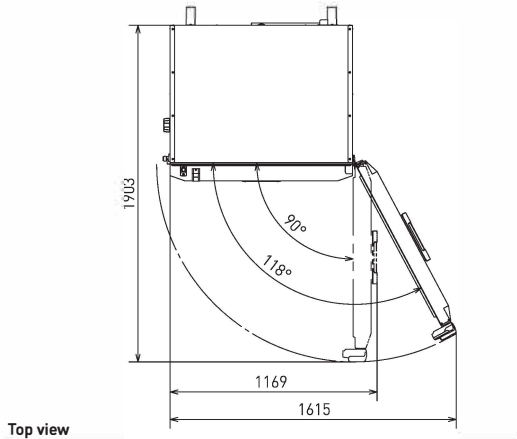

Top view

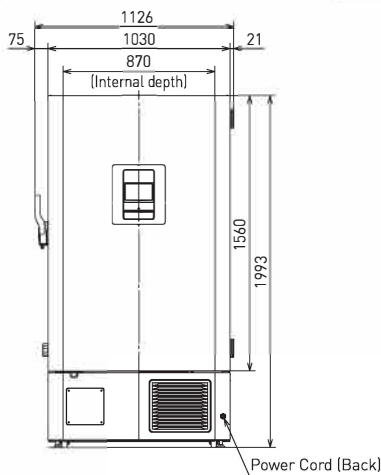

Front view

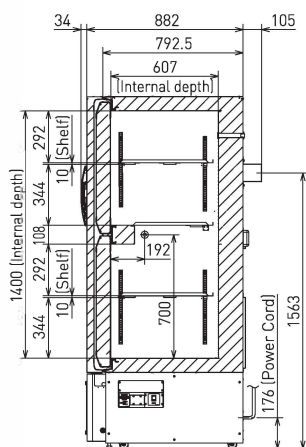

Side view

Model Number		MDF-DU700ZHA-PA
External dimensions (W x D x H) ¹⁾	mm	1030 x 882 x 1993
Internal dimensions (W x D x H)	mm	870 x 607 x 1400
Volume	liters	725
Net weight	kg	282
Capacity ²⁾	2" boxes	528
Performance		
Cooling performance ³⁾	°C	-86
Temperature setting range	°C	-90 to -40
Temperature control range ³⁾	°C	-86 to -40
Control		
Controller		Microprocessor with non-volatile memory
Display		LCD Touchpanel
Temperature sensor		Platinum resistance (Pt 1,000 Ω)
Refrigeration		
Refrigerant		HC
Insulation		Rigid polyurethane foamed-in place + Vacuum insulation panel
Construction		
Exterior material		Painted Steel
Interior material		Painted Steel
Outer door	qty	1
Outer door lock		Y
Inner doors	qty	2
Shelves	qty	3
Max. load - per shelf	kg	50
Vacuum release port		1 (manual)
Access port	qty	3
Access port position		back x1, bottom x2
Access port diameter	∅ mm	17
Casters	qty	4 (2 leveling feet)
Alarms (V = Visual Alarm, B = Buzzer Alarm, M = Message, R = Remote Alarm)		
Power failure		B-M-R
High temperature		V-B-M-R
Low temperature		V-B-M-R
Filter		V
Door open		V-B-M
Electrical and Noise Level		
Power supply	V	115
Frequency	Hz	60
Rated power consumption	W	460
Noise level ⁴⁾	dB (A)	52
Options		
Back-up cooling kit		MDF-UB7-PW ⁵⁾
Inventory rack		IR-220U-PW, MDF-24SR1-PW
Temperature recorder ⁶⁾	- Circular type	MTR-G85A-PA ⁶⁾ - Chart paper: RP-G85-PW - Ink pen: PG-R-PW
	- Continuous strip type	MTR-85H-PW ⁶⁾ - Chart paper: RP-85-PW - Ink pen: DF-38FP-PW - Recorder housing: MDF-S3085-PW
Recorder sensor cover		MTR-DU700SF-PW
Optional Communication Systems		
Digital interface (RS232C/RS485)		MTR-480-PW ⁷⁾
Ethernet interface (LAN)		MTR-L03-PW ⁷⁾

- 1) Exterior dimensions of main cabinet only, excluding handle and other external projections.
- 2) Usable storage capacity of 2" boxes when the original 3 trays installed.
- 3) Air temperature measured at freezer center, ambient temperature 30°C, no load.
- 4) Nominal value - Background noise 20 dB(A).
- 5) Settable range of the injection start temperature is -70°C to -50°C.

- 6) Requires sensor cover MTR-DU700SF-PW.
- 7) Standard signal and interface cables with a maximum length of 30 meters are recommended.

- Appearance and specifications are subject to change without notice.

Caution: PHC Corporation guarantees this product under certain warranty conditions. However, please note that PHC Corporation shall not be responsible for any loss or damage to the contents of the product.

DISTRIBUTED BY:

PHCbi
PHC Corporation